

AGEMASTER 60+60 RTX

LISTA DI RICAMBI
LIST OF SPARE PARTS
LISTE DES PIECES DE RECHANGE
ERSATZETEIL - LISTE
LISTA DE REPUESTOS

I

Come consultare il MANUALE PARTI DI RICAMBIO:

Il **Manuale Parti di Ricambio** è costituito da **Tavole grafiche** e da **Tablelle**.

Tavole grafiche:

- Le tavole riportano il disegno esploso dei gruppi principali della macchina.
- La suddivisione delle tavole è identificata nella TAV.0.
- Ogni particolare di ricambio è identificato da un **numero di posizione**, i **numeri di posizione posti in un riquadro identificano i particolari di ricambio consigliati**.

Tablelle:

- Le tablelle riportano i **Numeri di Posizione**, la **Descrizione** ed il **Codice** del particolare.
 - Nel caso in cui lo stesso numero di posizione sia riportato più volte, ma associato a codici differenti, è necessario, all'atto dell'ordine, specificare la matricola della macchina in possesso del cliente, al fine di identificare il codice del particolare da fornire.
- Per ordinare uno o più particolari di ricambio identificare sulla TAV.0 la tavola in cui è rappresentato il gruppo macchina in cui è presente il particolare, identificare quindi sulla tavola il particolare ed il relativo numero di posizione, quindi ricercare sulle tablelle il numero di posizione ed il corrispondente codice.*

GB

How o consult the SPARE PARTS MANUAL:

The **Spare Parts Manual** is made up of **Drawing Plates** and **Tables**.

Drawing Plates:

- The plates contain the exploded views of the main units comprising the machine.
- The subdivision of the plates is liste on "TAV.0".
- Each spare parts item is identified by a position number, position numbers found in a box indicate the spare parts items recommended.

Tables:

- The tables list the **Position numbers**, **Descriptions** and the **Codes** for items.
- When the same position number appears more than once, but is also associated with different codes, specify the serial number of the customer's machine when ordering for the purpose of identifying the code for the item to be supplied.

To order one or more spare part items, identify the plate on "TAV.0" representing the machine unit on which the item is located.

Locate the item on the plate and the corresponding position number as well. Then use the position number to locate the corresponding code on the table.

F

Comment consulter le LIVRET DES PIÈCES DÉTACHÉES:

Le livret des Pièces Détachées se compose de **Planches** et de **Tableaux**.

Planches:

- Les planches illustrent la vue éclatée des groupes principaux de la machine.
- La "TAV.0" illustre la subdivision des différentes planches.
- Chaque pièce détachée est identifiée par un numéro de repère; les numéros de repère en encadré identifient les pièces détachées conseillées.

Tableaux:

- Les tableaux indiquent les Numéros de repère, la Désignation des pièces et les Codes des pièces en question.
- Si la même numéro de repère indiqué plusieurs fois mais qu'il est associé à des codes différents, lors de la commande il faut préciser le numéro de série de la machine; cela permettra d'identifier le code de la pièce à fournir.

Pour commander une ou plusieurs pièces détachées, repérer sur la "TAV.0" la planche représentant le groupe dont fait partie la pièce, ensuite identifier la pièce en question sur la planche ainsi que son numéro de repère, puis rechercher sur les tableaux le numéro de repère et le code y relatif.

D

Hinweise für die Konsultation des ERSATZTEILHANDBUCHES

Das Ersatzteilhandbuch besteht aus graphischen **Abbildungen** und **Tabellen**.

Graphische Abbildungen:

- Die Abbildungen umfassen die Detailzeichnung der Hauptaggregate der Maschine
- Die Aufgliederung der Abbildungen ist in "TAV. 0" angegeben.
- Jedes Ersatzteildetail ist mit einer **Positionsnummer** identifiziert; **die eingerahmten Positionsnummern identifizieren die empfohlenen Ersatzteildetails**.

Tabellen:

- In den Tabellen sind die **Positionsnummern**, die **Beschreibung** und der **Code** des Teils aufgelistet.
- Ist dieselbe Positionsnummer mehrmals in Zusammenhang mit anderen Code angegeben, muß bei der Bestellung die Maschinennummer angegeben werden, um den Code des zu liefernden Ersatzteils ausfindig machen zu können.

Um eines oder mehrere Ersatzteile zu bestellen, anhand der "TAV.0" die Abb. feststellen, in der das Maschinenaggregat dargestellt ist, für das das Teil bestimmt ist; anhand dieser Abb. dann das Ersatzteil und die entspr. Positionsnummer identifizieren und schließlich in den Tabellen die Positionsnummer und den entspr. Code suchen.

E

COMO CONSULTAR EL MANUAL DE PIEZAS DE REPUESTO

El Manual Piezas de Repuesto está formado por **Tablas** gráficas y por **Cuadros**

Tablas gráficas

- Las tablas indican el dibujo expuesto individualmente en todos sus particulares (tridimensional) de los grupos principales de la máquina.
- La subdivisión de las tablas está identificada en la "TAV. 0".
- Cada pieza de repuesto se identifica por un **número de posición**, los **números de posición colocados en un recuadro identifican las piezas de repuesto aconsejadas**.

Cuadros

- Los Cuadros indican **los Números de Posición**, la **Descripción** y el **Código** de la pieza.
- En el caso de que el mismo número de posición esté indicado más de una vez, pero asociado a códigos diferentes, es necesario, en el momento del pedido, especificar la matricula de la máquina que posee el cliente, con el fin de identificar el código de la pieza que hay que suministrar.

Al hacer el pedido de una o más piezas de repuesto, identificar en la "TAV. 0" la tabla en la que está representado el grupo máquina en donde se halla la pieza, por consiguiente identificar en la tabla la pieza y el relativo número de posición, después buscar en los cuadros el número de posición y el correspondiente código.



AGEMASTER 60 + 60 RTX

Codice Macchina - Machine Code: 8454
Ed. 06/03

Pos.	Cod.	Descrizione	Description	Description	Bezeichnung	Descripcion
018	581800119	VALVOLA W 3/8"DANFOSS WVO10 003N6212	WATER VALVE	SOUPAPE A EAU	WASSERVENTIL	VALVULA AGUA
019	131165350	CONDENSATORE ARIA ECO D54517 "UL"	AIR CONDENSER	CONDENSATEUR A AIR	LUFT KONDENSATOR	CONDENSADOR AIRE
031	177110350	VALVOLA MEMBRANA SILIC. BIANCO	VALVE	SOUPAPE	VENTIL	VALVULA
049	171102250	BOTTONE ARRESTO MENSOLA	CUP HOLDER STUD	GOUJON BLOCAGE CONSOLE	KNPF KONSOLE	BOTON PARA PARADA REPISA
072	193010040	ESTRATTORE OR	O-RING EXTRACTOR	EXTRACTEUR DE JOINTS	O-RING AUSHEBER	EXTRACTOR
091	175100590	SPINA ALBERO AGITAZIONE	PIN	CHEVILLE	STIFT	CHAVETA
139A	173125130	ROS.PIANA 12 x 62 x 3 GOMMA	WASHER	RONDELLE	SCHEIBE	ARANDELA
139B	513800010	ROS.PIANA 10 x 23 x1,5 GOMMA	WASHER	RONDELLE	SCHEIBE	ARANDELA
140	581200820	CORPO VALVOLA SOLENOIDE EVR 3	SOLENOID VALVE BODY	CORPS ELECTROVANNE	KOERPER MAGNETVENTIL	CUERPO ELECTROVALVULA
141	581201016	BOBINA SOLENOIDE DANFOSS 220V-50/60	SOLENOID VALVE COIL	BOBINE ELECTROVANNE	SPULE MAGNETVENTIL	BOBINA ELECTROVALVULA
147	584200121	CONDENS. W HPCR 1104 TR	WATER CONDENSER	CONDENSATEUR EAU	WASSERKONDENSATOR	CONDENSADOR AGUA
159	155101680	ALBERO TRASMISSIONE MOTO	DRIVE SHAFT	ARBRE DE TRANSMISSION	ANTRIEBSWELLE	ARBOL DE TRANSMISION
161	529410305	BOCCOLA MB 08.12 DU/B	BUSHING	COQUILLE	BUCHSE	CASQUILLO
161A	529410307	BOCCOLA MB 14.20 DU/B	BUSHING	COQUILLE	BUCHSE	CASQUILLO
161B	157135460	BOCCOLA PASSATUBO	BUSHING	COQUILLE	BUCHSE	CASQUILLO
161C	157120190	BOCCOLA COLLEGAMENTO ALBERO E MOTORE	BUSHING	COQUILLE	BUCHSE	CASQUILLO
162	155103210	ALBERO VENTOLA AGITAZIONE	MIX TANK AGITATOR	AGITATEUR CUVE	RUEHRWERKSBEHAELTER	AGITADOR MEZCLA EN CUBA
163	164130920	GUIDA ALBERO AGITATORE	AGITATOR SHAFT HOUSING	GUIDE ARBRE	WELLENFUERUNGSMANTEL	GUIA ARBOL
168	561182620	C.UNITE H.CAJ4519Z 220240/50/1	COMPRESSOR	COMPRESSEUR	KOMPRESSOR	COMPRESOR
168	561182640	C.UNITE H.CAJ4519Z	COMPRESSOR	COMPRESSEUR	KOMPRESSOR	COMPRESOR



AGEMASTER 60 + 60 RTX

Codice Macchina - Machine Code: 8454
Ed. 06/03

Pos.	Cod.	Descrizione	Description	Description	Bezeichnung	Descripcion
		208220/60/1				
170	552990150	M.VENT.ZIEHL A4E300-AP26 230/5060/1	FAN MOTOR	MOTEUR VENTILATEUR	VENTILATOR MOTOR	MOTOR VENTILADOR
173	571100238	CONTATTORE A16-30-10-80 230-50/60HZ	CONTACTOR	CONTACTEUR	KONTAKTOR SCHUTZ	CONTACTOR
177	583100148	PRESS.DANFOSS CC20W 29/20 060F1130	PRESSURE SWITCH	PRESSOSTAT	DRUCKWAECHTER	PRESOSTATO
186	192113100	DECALC.FRONTALE AGEMASTER 60+60 RTX	FRONT PANEL DECAL	DECALCOMANIE FRONTALE	ABZIEHBILD	CALCOMANIA
200	573810163	MICROPROC.ST72T331J2 VER.AGMXX.BIN	MICROPROCESSOR	MICROPROCESSEUR	MIKROPROZESSOR	MICROPROCESADOR
231	158270080	FLANGIA RIDUTTORE	FLANGE	BRIDE	FLANSCH	BRIDA
236	588300336	SOTTOTAPPO PLASTICA D.19	PLUG	BOUCHON	VERSCHLUSS	TAPON
236A	588300340	SOTTOTAPPO PLASTICA D.26	PLUG	BOUCHON	VERSCHLUSS	TAPON
240	591000225	RUOTA 80x25 C/B SCR/FIL. M12	PIVOTING WHEEL	ROUE	SCHWENKBARES RAD	RUEDA
241	591000125	RUOTA 80x25 C/B SF 80/M	FIXED WHEEL	ROUE	FIXES RAD	RUEDA
250	102144790	COPERCHIO VASCA	TANK COVER	COUVERCLE CUVE	BEHAELTERDECKEL	TAPA TANQUE
253	102127690	CERNIERA FISSA DX	HINGE	CHARNIERE	SCHARNIER	BISAGRA
253A	102127760	CERNIERA FISSA SX	HINGE	CHARNIERE	SCHARNIER	BISAGRA
253B	102127700	CERNIERA FISSA CENTRALE	HINGE	CHARNIERE	SCHARNER	BISAGRA
255	171102290	VITE SPECIALE	SCREW	VIS	SCHRAUBE	TORNILLO
255A	171115010	VITE MOLLA NOTTOLINO	SCREW	VIS	SCHRAUBE	TORNILLO
276*	588210050	MORSETTO DOPPIO K12 3/4	STOP	DISPOSITIF D'ARRET	HEMMVORRICHTUNG	ARRESTO
278	178150270	MOLLA FLANGIA RUBINETTO	TAP SPRING	RESSORT	FEDER HAHNFLANSCH	RESORTE
287*	171195870	PORTAGOMMA	SPIGOT HOSE CONNECTOR	RACCORD POUR TUYAUX	ROHRTRAEGER	PORTAGOMA
287B	588150332	PORTAGOMMA L PLASTICA 1/2FxD.12	SPIGOT HOSE CONNECTOR	RACCORD POUR TUYAUX	ROHRTRAEGER	PORTAGOMA
329	542000148	ANELLO ANGUS A 8X16X7	O-RING	BAGUE DE RETENUE	SPEZ. DICHTUNGSRING	ANILLO RETEN
351	589100246	DOCCIA ANTEA BIANCA ART.D0100/B	WATER DISPENSER	DISTRIBUTEUR D'EAU	ENDSTUECK WASSERZUFUHR	DESPENSADOR DE AGUA



AGEMASTER 60 + 60 RTX

Codice Macchina - Machine Code: 8454
Ed. 06/03

Pos.	Cod.	Descrizione	Description	Description	Bezeichnung	Descripcion
352*	549000529	GUARNIZIONE K34 3/4	SEAL	GARNITURE	DICHTUNG	GUARNICION
352A	158195050	GUARNIZIONE	SEAL	GARNITURE	DICHTUNG	GUARNICION
352B	549000112	GUARNIZIONE 12x18x1,5	SEAL	GARNITURE	DICHTUNG	GUARNICION
370	102154310	COP. ALBERO VENTOLA	COVER	COUVERCLE	DECKEL	TAPADERITA
375	161165060	MANICOTTO RIDUZIONE	COUPLING	MANCHON	MUFFE	MANGUITO
424	589800129	TUBO PLASTICA D.10/16 RINFORZATO	PIPE	TUBE	SCHLAUCH	TUBO
424A	589110031	TUBO DOCCIA MONOFORO MF 3/8" L=2mt.	PIPE	TUBE	SCHLAUCH	TUBO
424B*	157230560	TUBO GOMMA ALIMENTARE D.14/19 2mt.	PIPE	TUBE	SCHLAUCH	TUBO
425	581300302	ELETTROVALVOLA ELBI ART.329000 EV	WATER SOLENOID VALVE	ELECTROVANNE A EAU	MAGNETVENTIL	ELECTROVALVULA AGUA
425A	581300303	ELETTROVALVOLA ELBI TIPO 340-9000 220V	WATER SOLENOID VALVE	ELECTROVANNE A EAU	MAGNETVENTIL	ELECTROVALVULA AGUA
425A	581300304	ELETTROVALVOLA ELBI 90° DOPPIA 24V	WATER SOLENOID VALVE	ELECTROVANNE A EAU	MAGNETVENTIL	ELECTROVALVULA AGUA
433	178100260	MOLLA C I 1,3 15 40 3,68	SPRING	RESSORT	FEDER	RESORTE
447	155130490	ASTA RUBINETTO	ROD	TIGE	STIFT	VARILLA
450	173105060	POMELLO RUBINETTO	FAUCET KNOB	POMMEAU ROBINET	HAHNGRIFF	BOTON DE GRIFO
459	177110370	VALVOLA CHIUSURA RUBINETTO	CLOSING TAP VALVE	SOUPAPE FERMETURE ROBINET	HAHN ABSPERRVENTIL	VALVULA DE CIERRE DE GRIFO
475	599900161	VALIGETTA CORREDO	ACCESSORIES	ACCESSOIRES	ZUBEHOERTEILE	ACCESORIOS
500	558420033	RIDUTTORE TR10 1:30 GAVAGNI	GEAR BOX	REDUCTEUR	GETRIEBE	REDUCTOR
575	573800530	PULSANTIERA MOD. AGEMASTER TASTI RAFI	PUSH-BUTTON PANEL	CLAVIER	TASTATUR	CAJA DE PULSADORES
600	558420153	MR.MTR 10 1:30 CL.F 220/5060/1	REDUCTION GEAR BOX	MOTO-REDUCTEUR	MOTORGETRIEBE	MOTORREDUCTOR
605	573700193	CENTRALINA AGEMASTER RTX	ELECTRONIC BOARD	CENTRALE ELECTRONIQUE	ELEKTRONISCHE STEUERKASTE	CENTRALITA ELECTRONICA
607	572910101	SONDA TS TIPO P09251	PROBE	SONDE	FUEHLER	SONDA



AGEMASTER 60 + 60 RTX

Codice Macchina - Machine Code: 8454
Ed. 06/03

Pos.	Cod.	Descrizione	Description	Description	Bezeichnung	Descripcion
		C.SILIC.				
772	599100123	SCOVOLINO D. 30x640	FINE BRUSH	ECOUVILLON	REINIGUNGSBUERSTE	CEPILLO
772A	599100112	SCOVOLINO D. 12x35x280 ELICOIDALE	FINE BRUSH	ECOUVILLON	REINIGUNGSBUERSTE	CEPILLO
830	743000111	TUBETTO GELILUBE 3540180	FOOD GRADE LUBRICANT	TUBE DE VASELINE	GELILUBE TUBE	TUBO GELILUBE
840	178600160	SPATOLA PULIZIA	SPATULA	SPATULE	SPATEL	PALETA
912	552120153	M.CARP.M56 4 B14 220/50-60/1	MOTOR FOR GEAR BOX	MOTEUR POUR REDUCTEUR	MOTOR FUER MOTORGETRIEBE	MOTOR MOTORREDUCTOR
921	572910140	SONDA DRY REED N.O. 29	SAFETY SWITCH	SONDE DRY REED	REEDFUEHLER	SONDA DRY REED
924	155280010	NOTTOLINO	PLUG	CLIQUET	KLINKE	TRINQUETE
1225	541000225	OR 3,53 32,93 NB 70 4131	O-RING	JOINT OR	OR-DICHTUNG	JUNTA OR

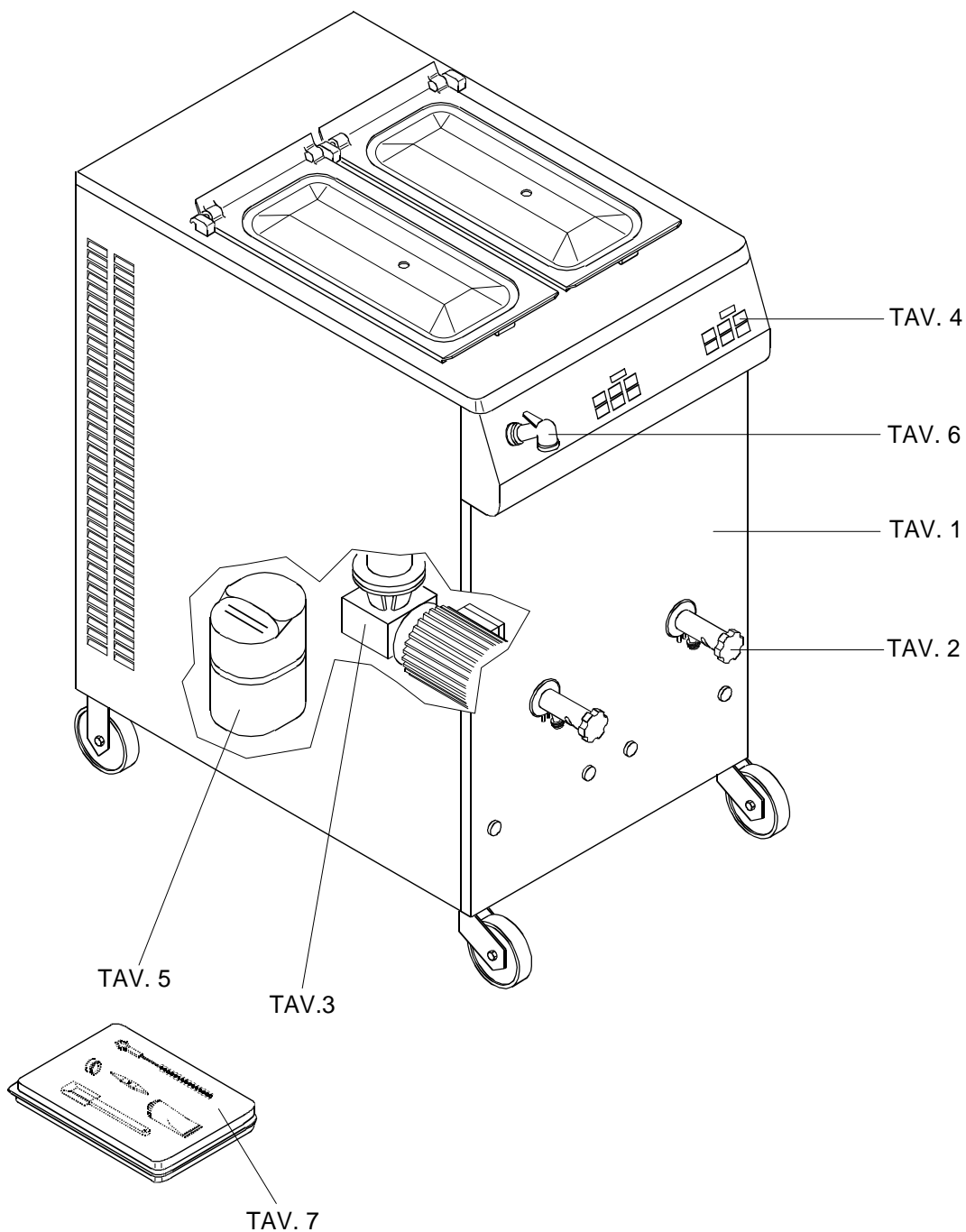

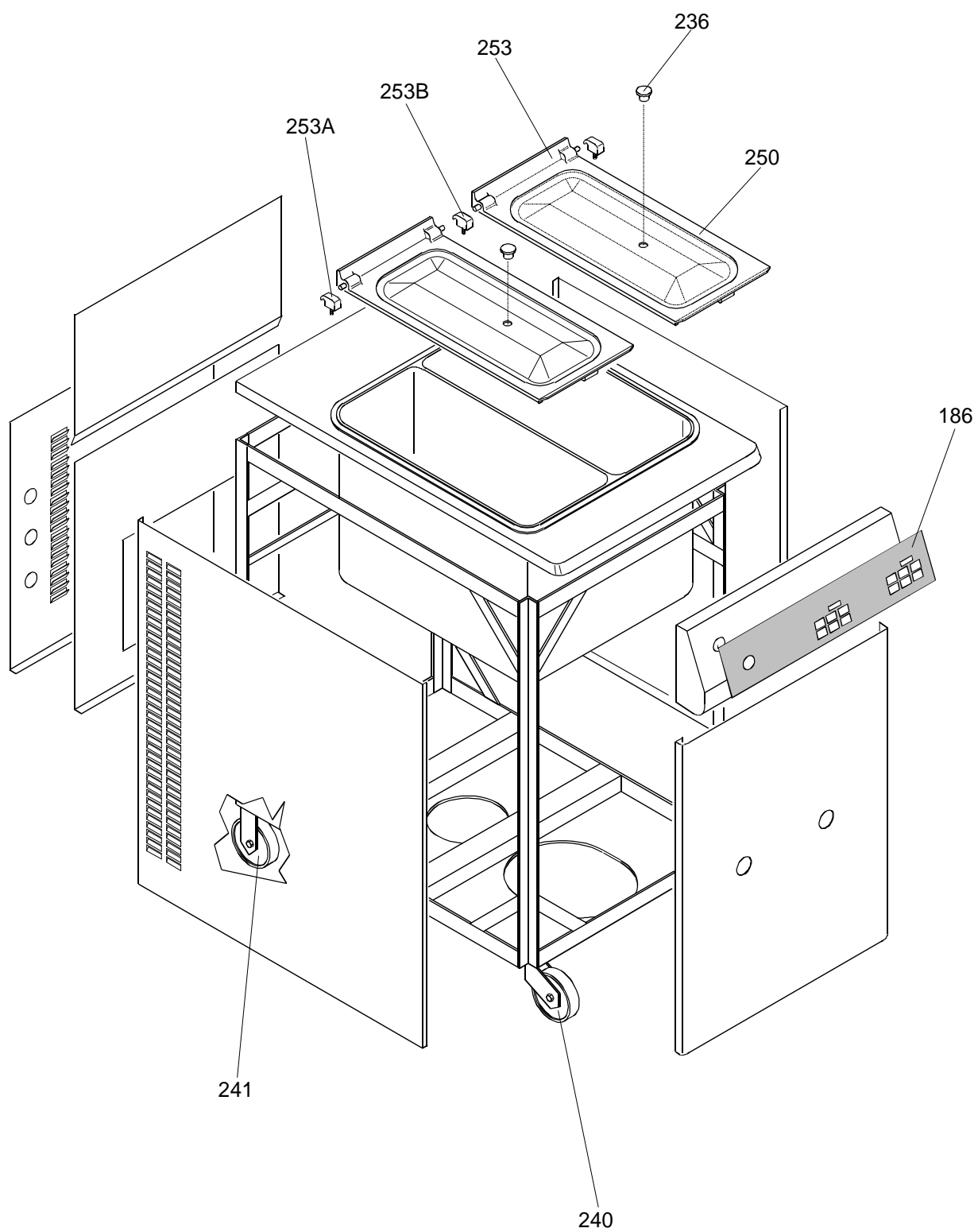

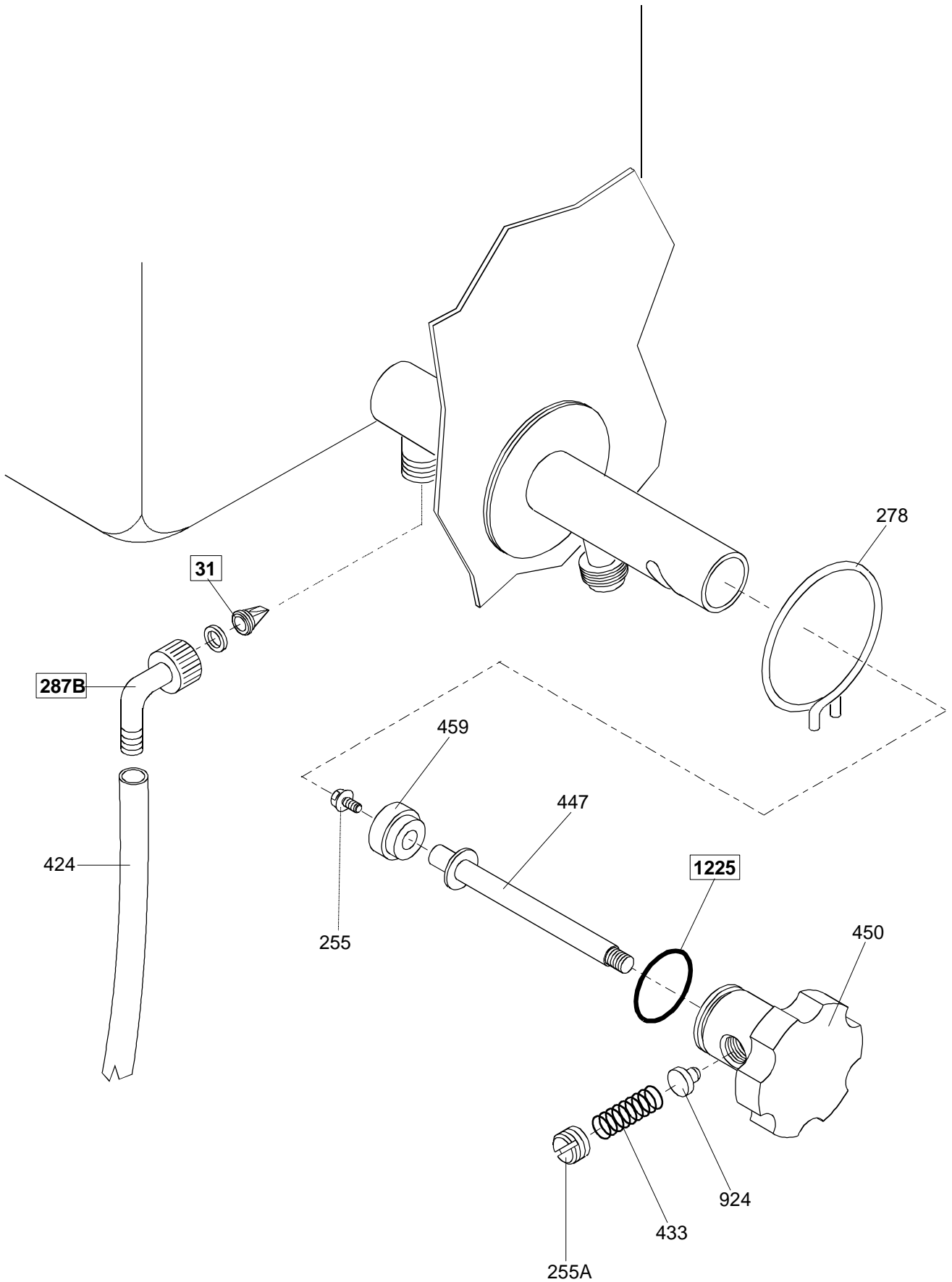

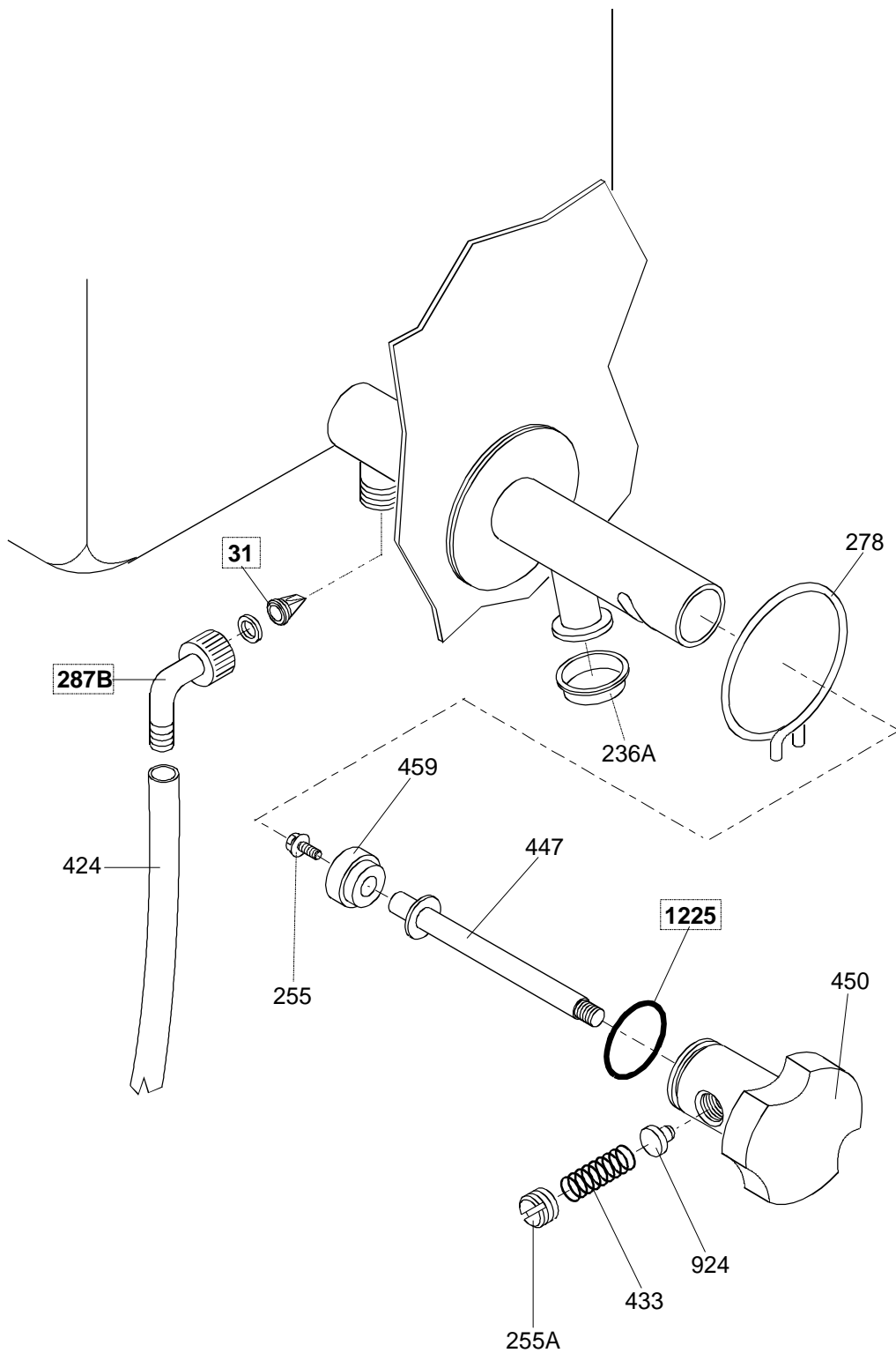

*OPZIONAL

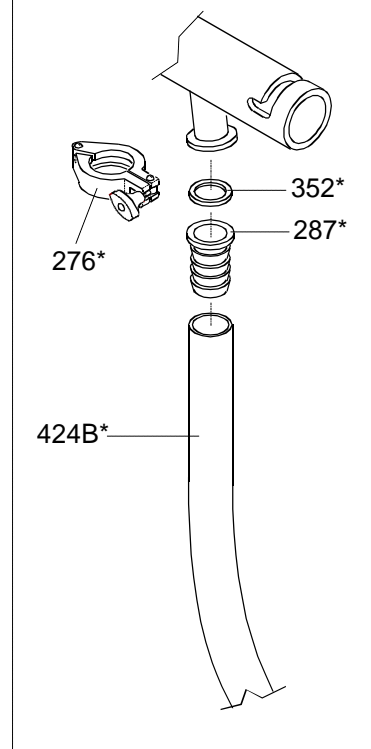

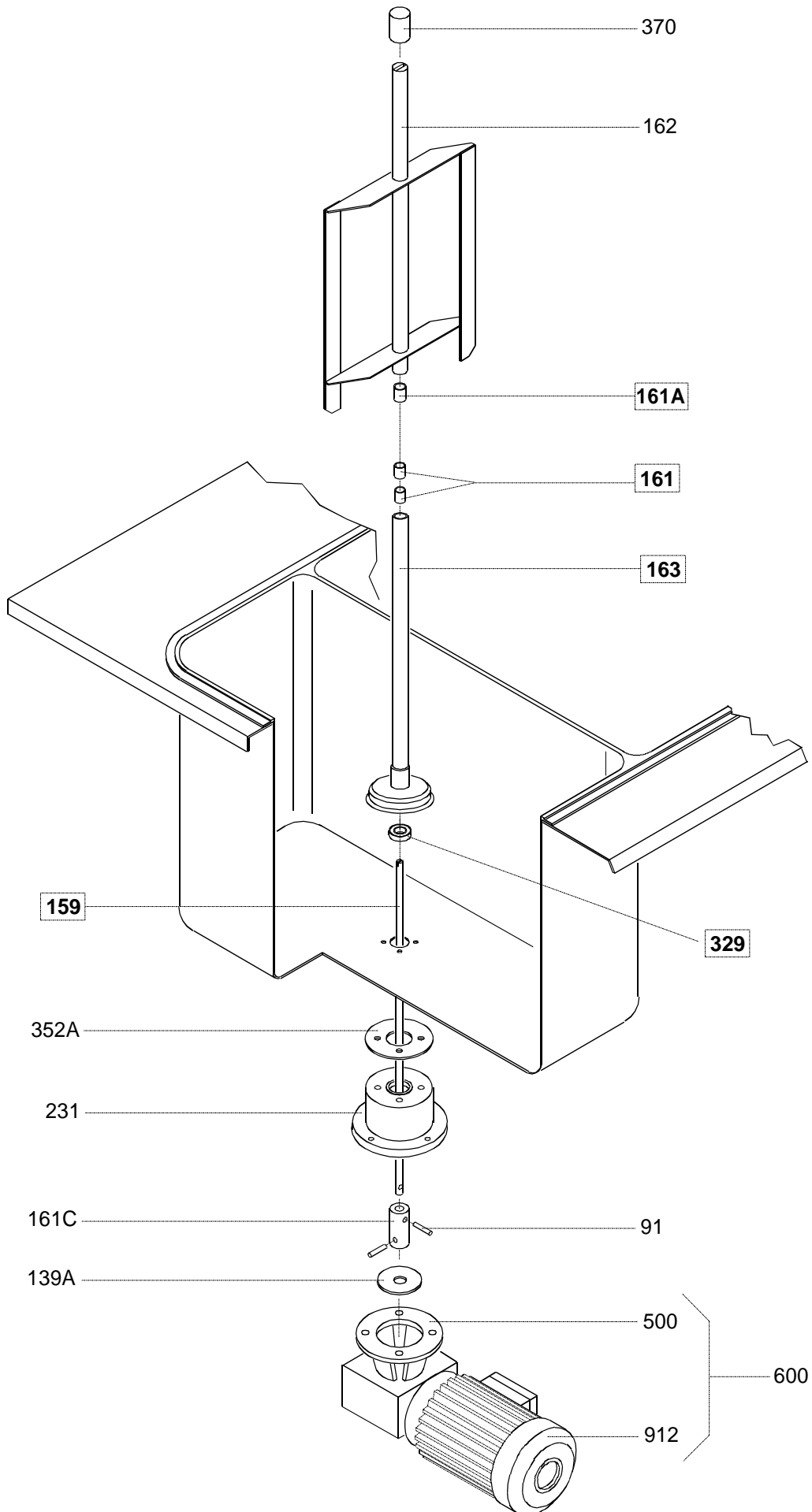

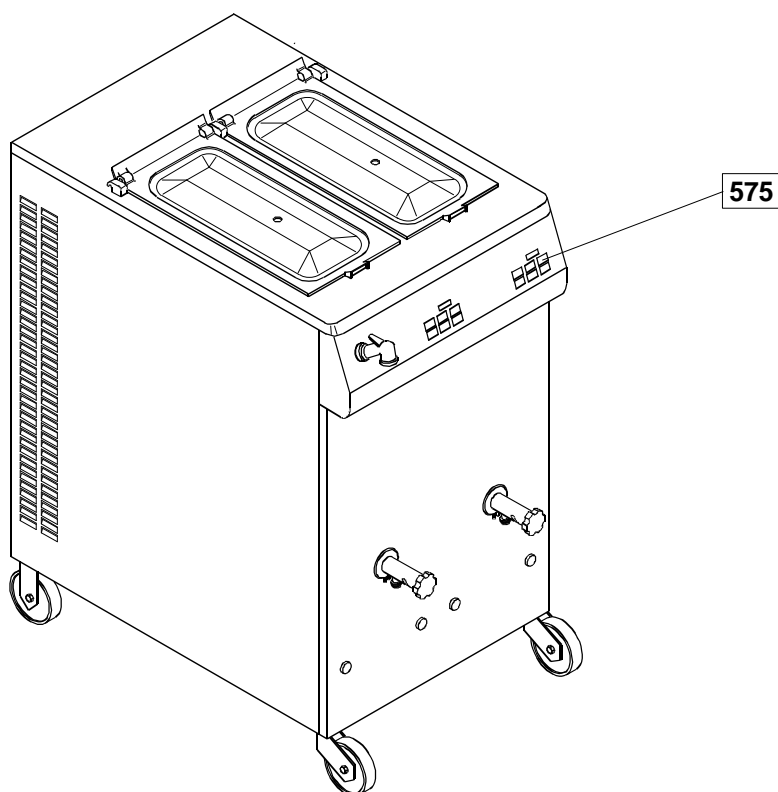
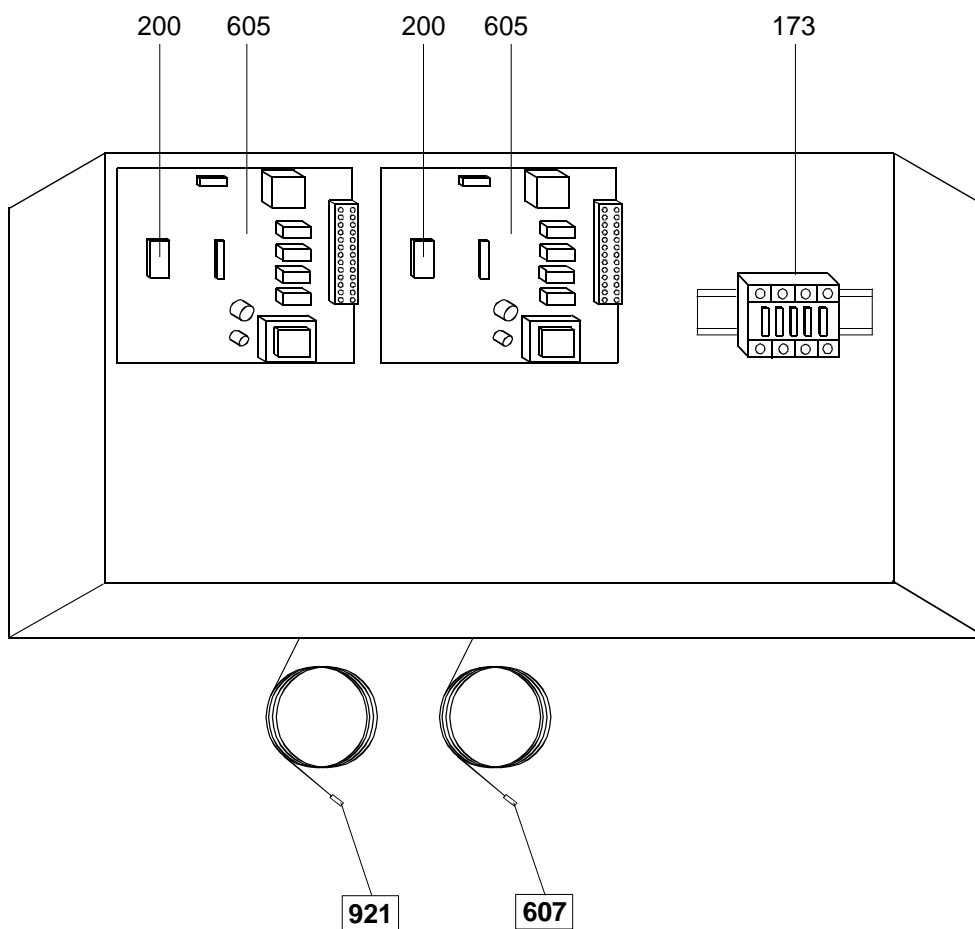

IMPIANTO FRIGORIFERO

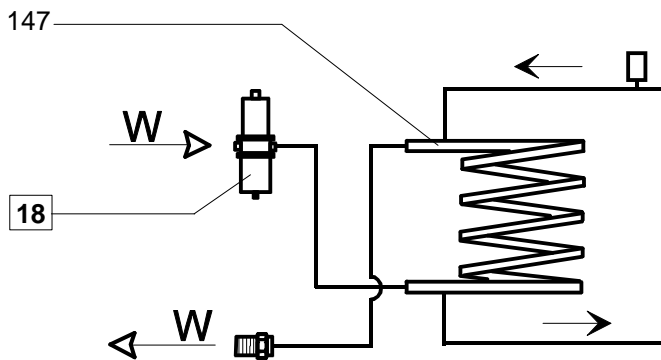
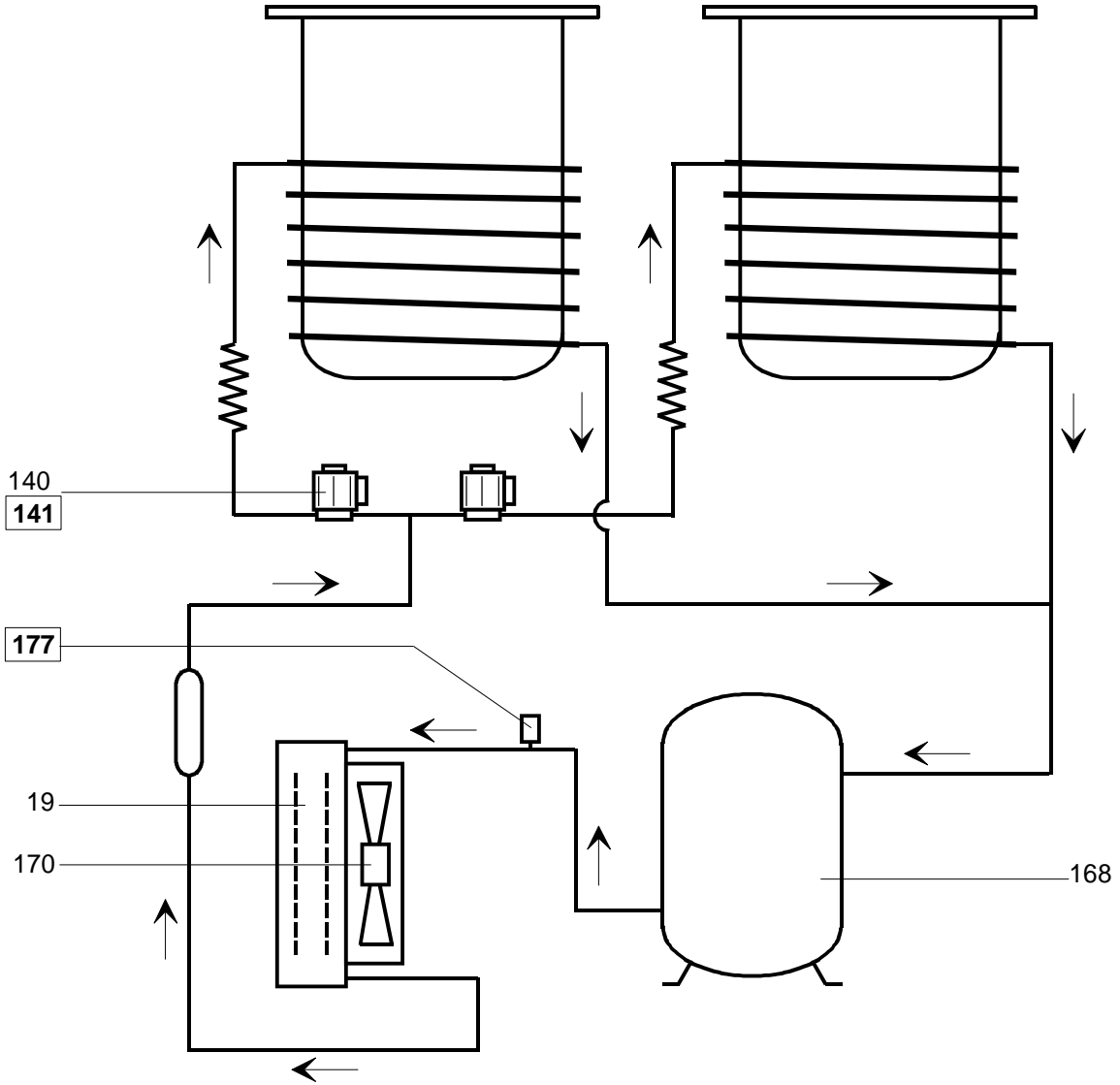

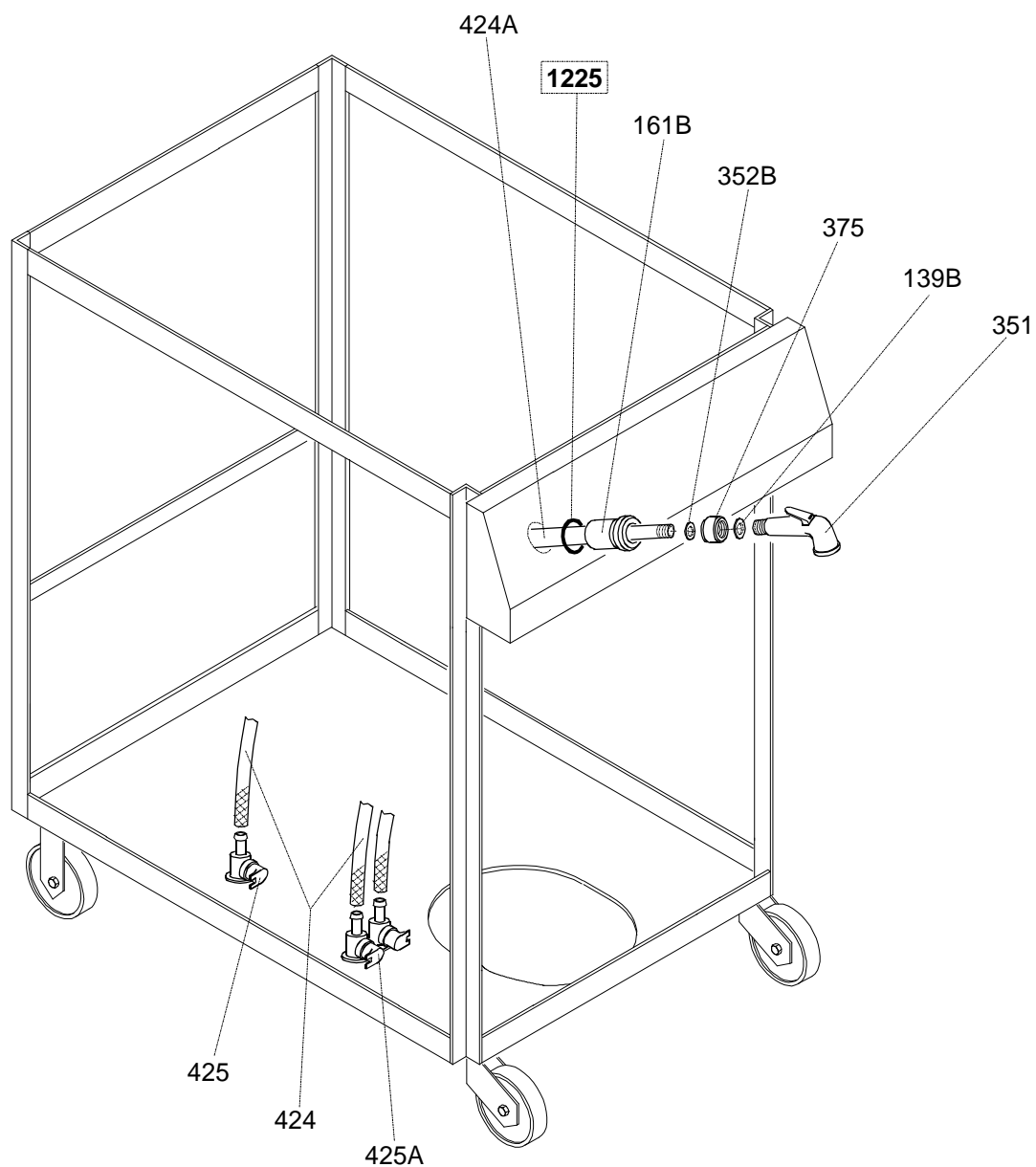

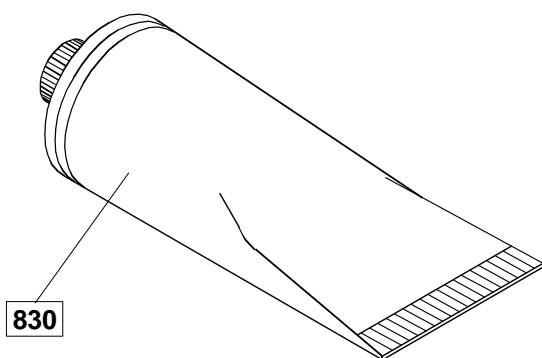
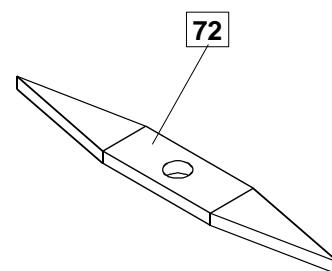
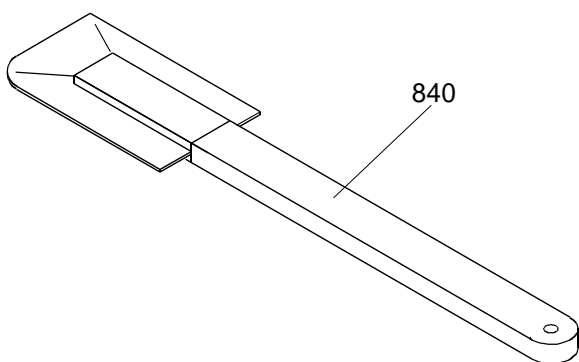
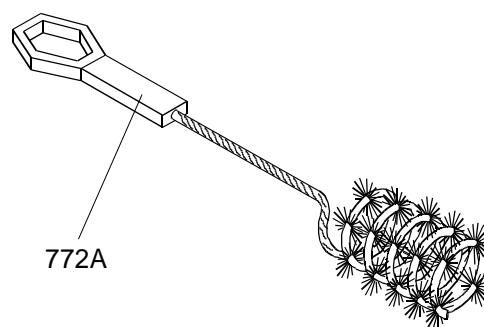
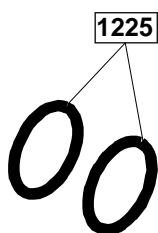
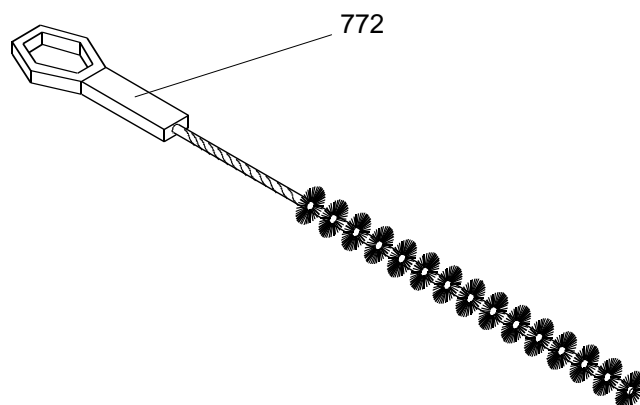
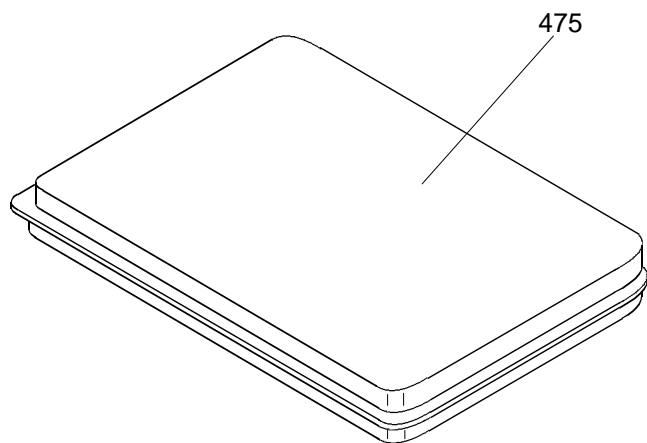



CARPIGIANI - ALI GROUP S.p.A.
Via Emilia, 45
40011 Anzola Emilia (Bologna) - Italy
Tel. (051) 6505111
Fax (051) 732178

Carpigiani si riserva il diritto di effettuare modifiche e/o revisioni del presente documento senza obbligo di preavviso.
Carpigiani reserves the right to make change and/or revisions of this document without being bound to previously notify it.
Carpigiani se réserve le droit d'apporter toutes modification et mises à jour jugées nécessaires et ce, à tout moment et sans obligation de préavis.
Carpigiani behält sich das Rech vor, jederzeit Änderungen ohne Voranzeige vorzunehmen.
Carpigiani se reserva el derecho de efectuar modificaciones y actualizaciones todas la veces que lo considere necesario sin la obligación de peraviso.